

HE-35 – HE-250



Vacuum Hose Lifter Components

Lifting Hose Units HE

For use with the Jumbo Travelling Crane JWK, the JUMBOMOBIL JM or on any other crane carrier.
(Application of lifting hose unit HE-250 is permissible at stationary crane facilities only, not to be operated with JUMBOMOBIL, JUMBO-BV and Jumbo Travelling Crane JWK).

Consists of:

- ▶ Transportation hook.
- ▶ Rotational Device and quick coupling, 2 inch.
- ▶ Lifting hose unit with protective fabric as well as a flange for fitting onto the operating valve unit.

Type	Working Load Limit WLL* kg (lbs)	Diameter Lifting Hose mm (in)	Lifting Height mm (in)	Order-Number
HE-35	35*** (75)***	120 (5")	1,700 (67")	4210.0001
HE-50	50*** (110)***	140 (5 1/2")	1,700 (67")	4210.0106
HE-85	85*** (185)***	178 (7")	1,700 (67")	4210.0002
HE-150	150*** (330)***	230 (9")	1,500 (59")	4210.0132
HE-200	200*** (440)***	250 (9 3/4")	1,500 (59")	4210.1114
HE-250	250*** (550)***	300 (11 3/4")	1,500 (59")	4210.1115
If necessary: roller suspension for C-beam				4220.0042

BE-Sprint-2



Operating Valve Unit BE-Sprint-2

- ▶ For direct coupling onto the lifting unit HE.

Consists of:

- ▶ Main body with handle 500 mm long, fixing screw for adjusting the hovering position, safety gauge.

Type	For use with	Order-Number
BE-Sprint-2	HE-35 up to HE-250	4210.0539

SZV



Hose Cylinder Extension SZV

- ▶ Only to be used as and when required to enable ergonomic working conditions, at certain heights.
- ▶ Length 300 mm

Consists of:

- ▶ Vacuum pipe with quick fasteners and transmission bar for the steering of the operating valve unit.

Type	For use with	Order-Number
SZV	HE-35 up to HE-150	4210.0007
SZV-250	HE-200 up to HE-250	4210.0008

SWV-HE

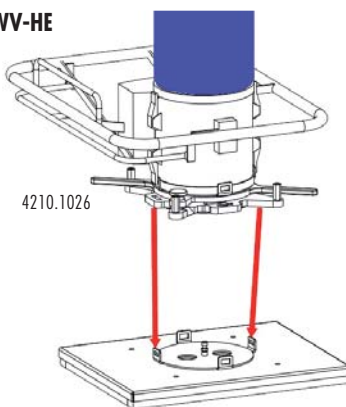

Quick Change Device SWV-HE

Suction plates are usually fixed to the operating valve unit BE or hose cylinder extension SZV through two hook latches.

In case suction plates have to be changed continually, the quick change device SWV-HE is highly recommended.

- ▶ Faster suction plate changing with a simple twisting motion.
- ▶ Suitable for all lifting hose units from HE-35 to HE-250.

- ▶ Easy operation, no inconvenient screwing of adapters required.

- ▶ Operating errors no longer possible.
- ▶ When using lifting hose units HE-200 and HE-250, the operating valve unit is fitted directly to the SWV-HE quick change device by means of 4 tension rods (threaded rods).

Type		Working Load Limit WLL kg (lbs)	Dead Weight kg (lbs)	Order-Number
SWV-HE	Quick change device	250 (550)	3,8 (8)	4210.1026

* Caution: Take note of the working load limit of the crane equipment. ***Value at 420 mbar low pressure

011016 Technical data contained in this catalogue can be modified without prior notice in the interest of progress. No liability accepted for any misprints, mistakes and errors.