

# **KD SERIES™ ENGINES**

**for Industrial Power Systems**

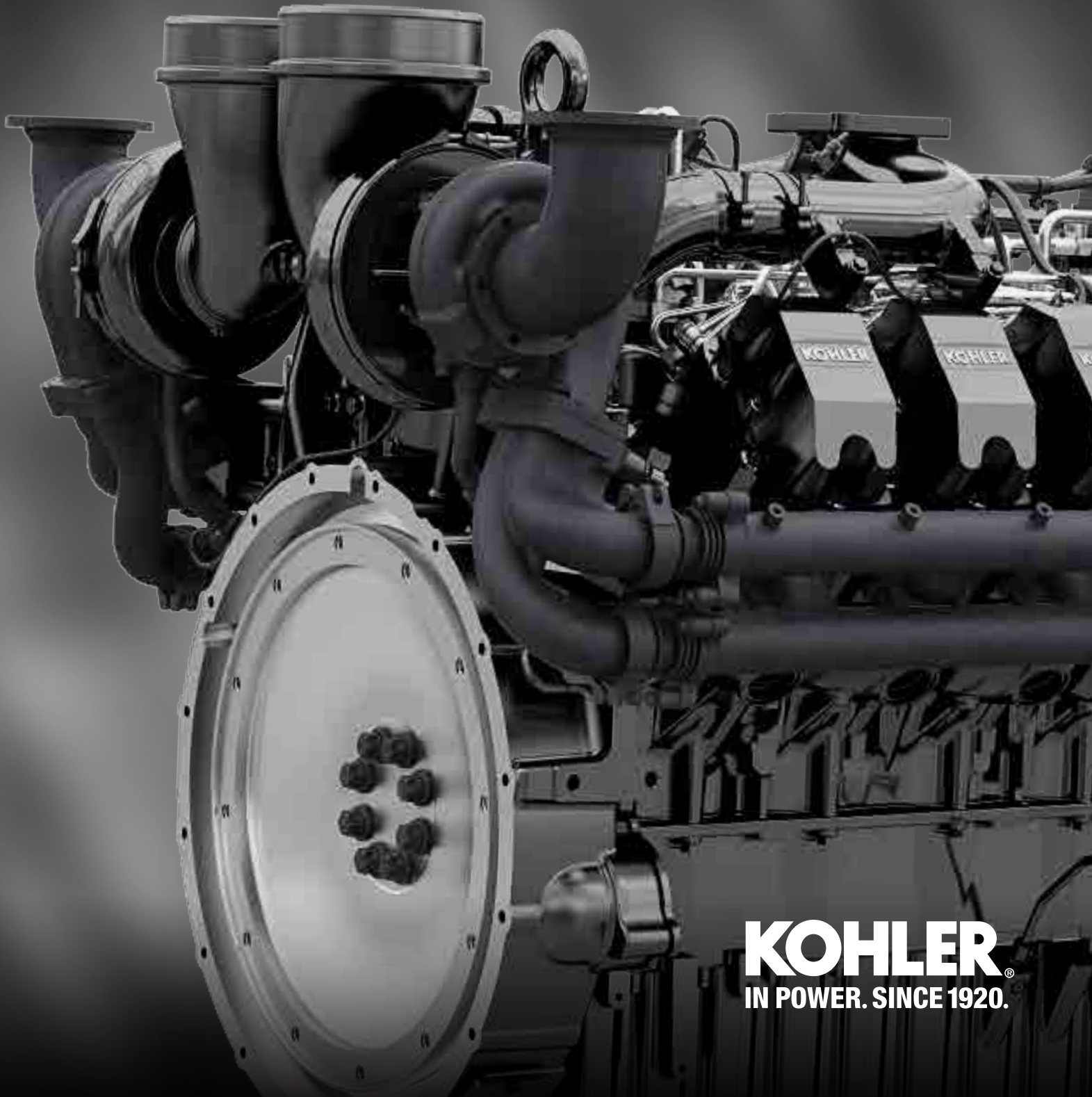

**KOHLER®**  
IN POWER. SINCE 1920.

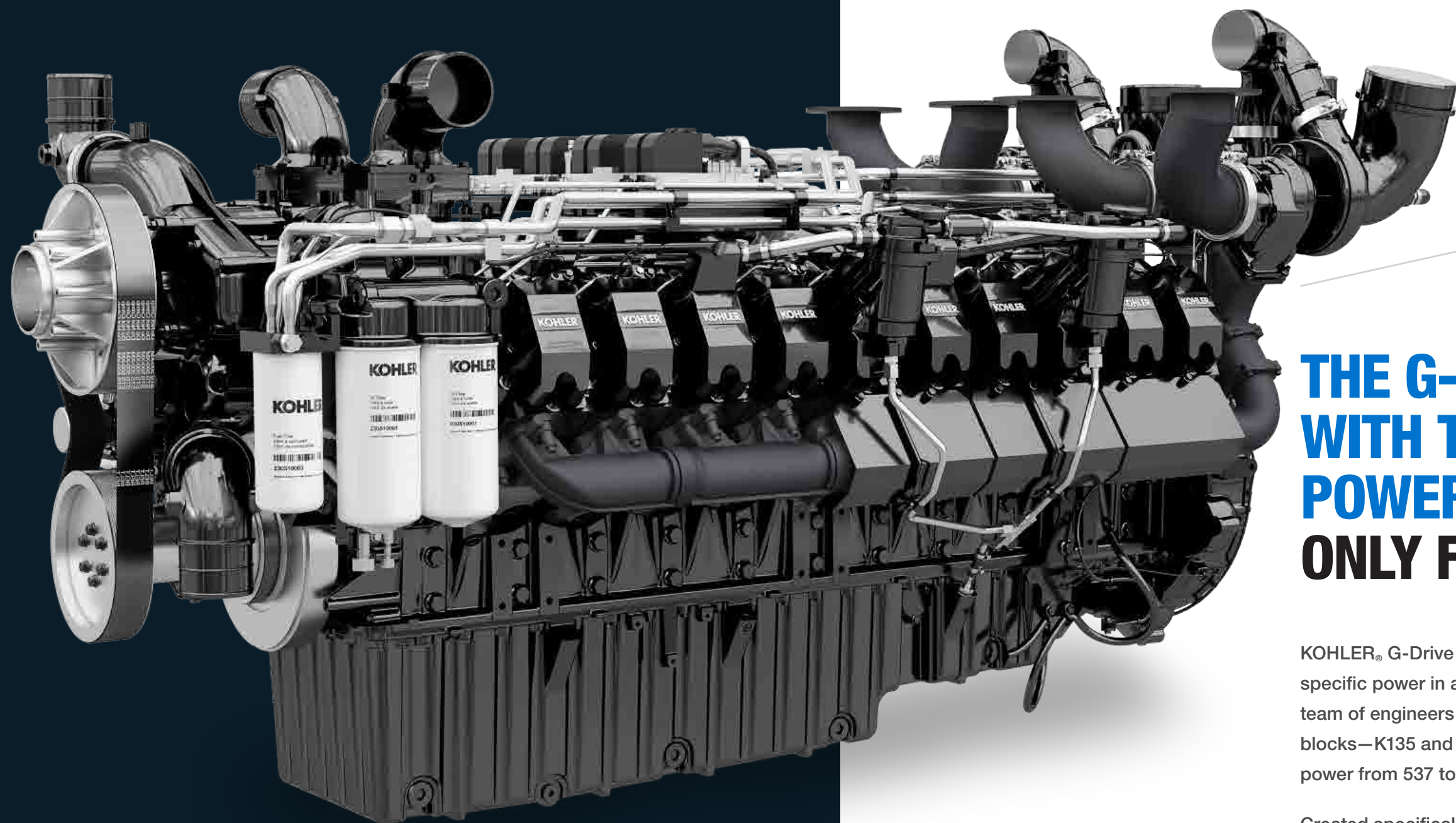

## **THE G-DRIVE ENGINE WITH THE HIGHEST POWER DENSITY.\* ONLY FROM KOHLER.**

KOHLER® G-Drive diesel engines offer outstanding specific power in a clean, modular design. Our global team of engineers developed two sophisticated engine blocks—K135 and K175—that deliver a large range of power from 537 to 4250 kWm.

Created specifically for generator set applications, these new engines combine greater power with superior efficiency. Reaching up to 43.5 kW/liter, KOHLER G-Drive engines pair a compact form factor with unrivaled kW displacement—delivering the highest power density on the market.\*

*\*Higher power density at more nodes than any competitor between 800–2500 kW.*

# PERFORMANCE

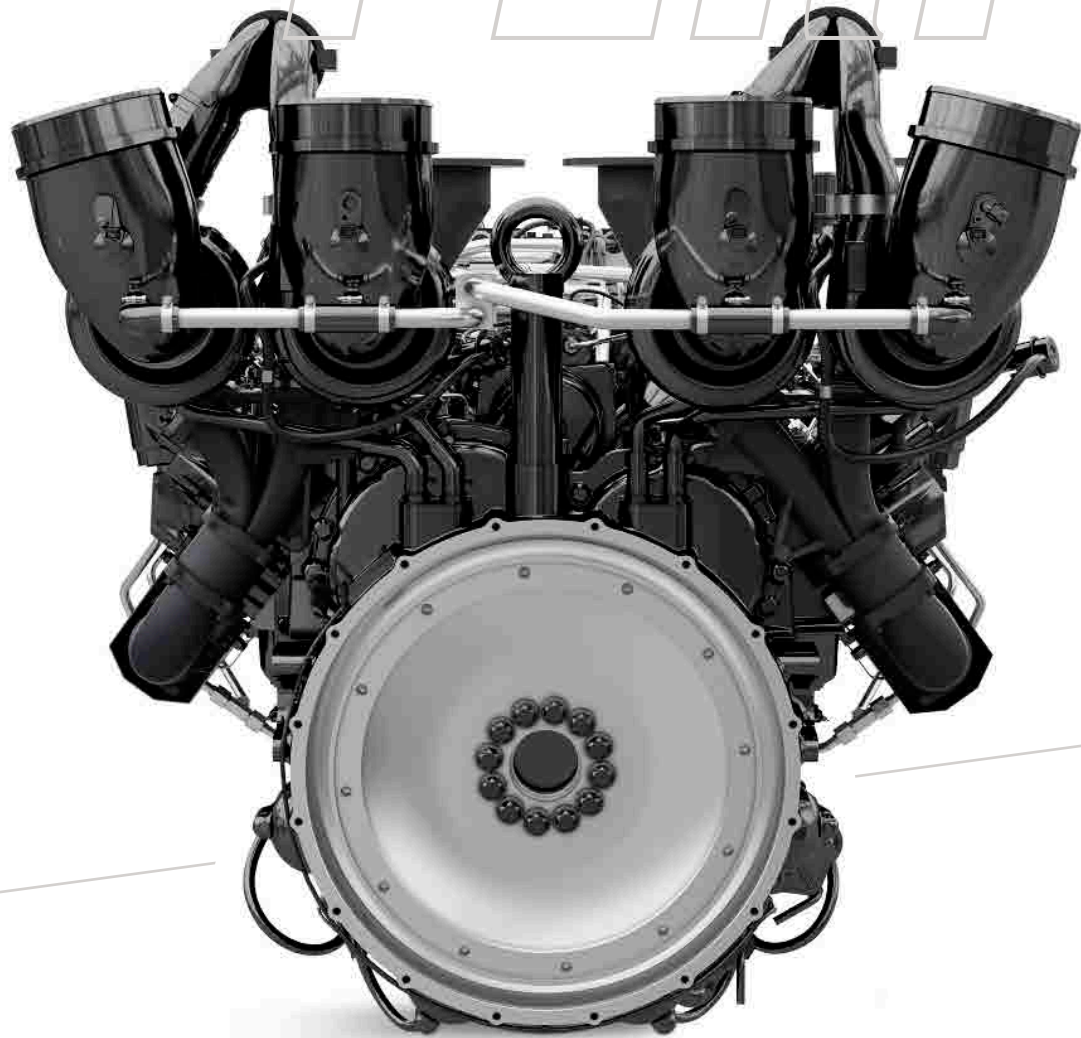

## CONCENTRATED POWER

The KOHLER® G-Drive diesel engine range produces industry-leading kW displacement in a package that enables a smaller generator set footprint while delivering the best fuel consumption at more nodes than any competitor between 800–2500 kW. That means higher performance at reduced operating cost. The engine architecture, injection system and engine management of G-Drive engines have been designed to achieve optimal generator set performance while meeting all worldwide emission requirements.

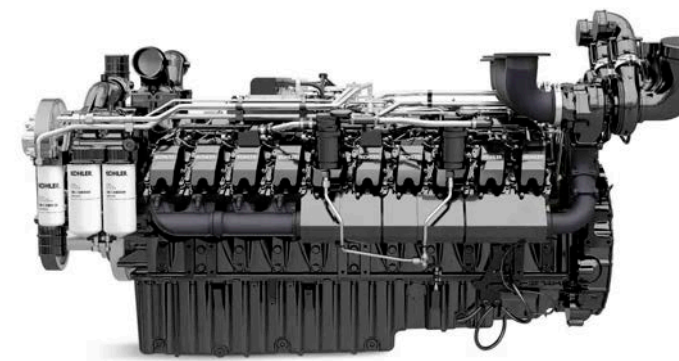

## ROBUST AND RELIABLE

With almost a century of engineering know-how behind it, our G-Drive engine has been purposefully designed for long-life performance inside your KOHLER® or SDMO® generator—power systems that are backed by a three-year emergency standby power (ESP) warranty. We design, test and fit every component. Our computer-aided quality-management system oversees every step of development, from the first stage of production through the engine's entire lifecycle, to ensure the highest level of quality.

## MODULAR DESIGN

All models within the KD Series™ are designed to share common components including engine control units, connecting rods and pistons, fuel system components, cylinder heads and more. This sophisticated, modular design means more efficient servicing of the engine, reduced spare parts inventory and more streamlined technician training.

## SMOOTH RUNNING

Our G-Drive engine runs smoothly, quietly and with low vibration—even under extreme operating conditions. Vibration is minimized through low-noise combustion and optimized combustion pressure. The rigid design of the engine block, crankcase, oil sump, valve cover and subframe also helps reduce vibration.

Unlike engines with standard crankshaft support-bearing configurations, the KOHLER G-Drive offers an optimized bearing arrangement, creating a more stable engine with less vibration.

## LOW OPERATING AND MAINTENANCE COSTS

Costs to operate and maintain a KOHLER G-Drive engine are reduced through low fuel consumption, increased power density, reduced acquisition costs and diagnostics that help prevent issues. The cylinder head design and crankcase ventilation mean extended service intervals and longer lifetime.

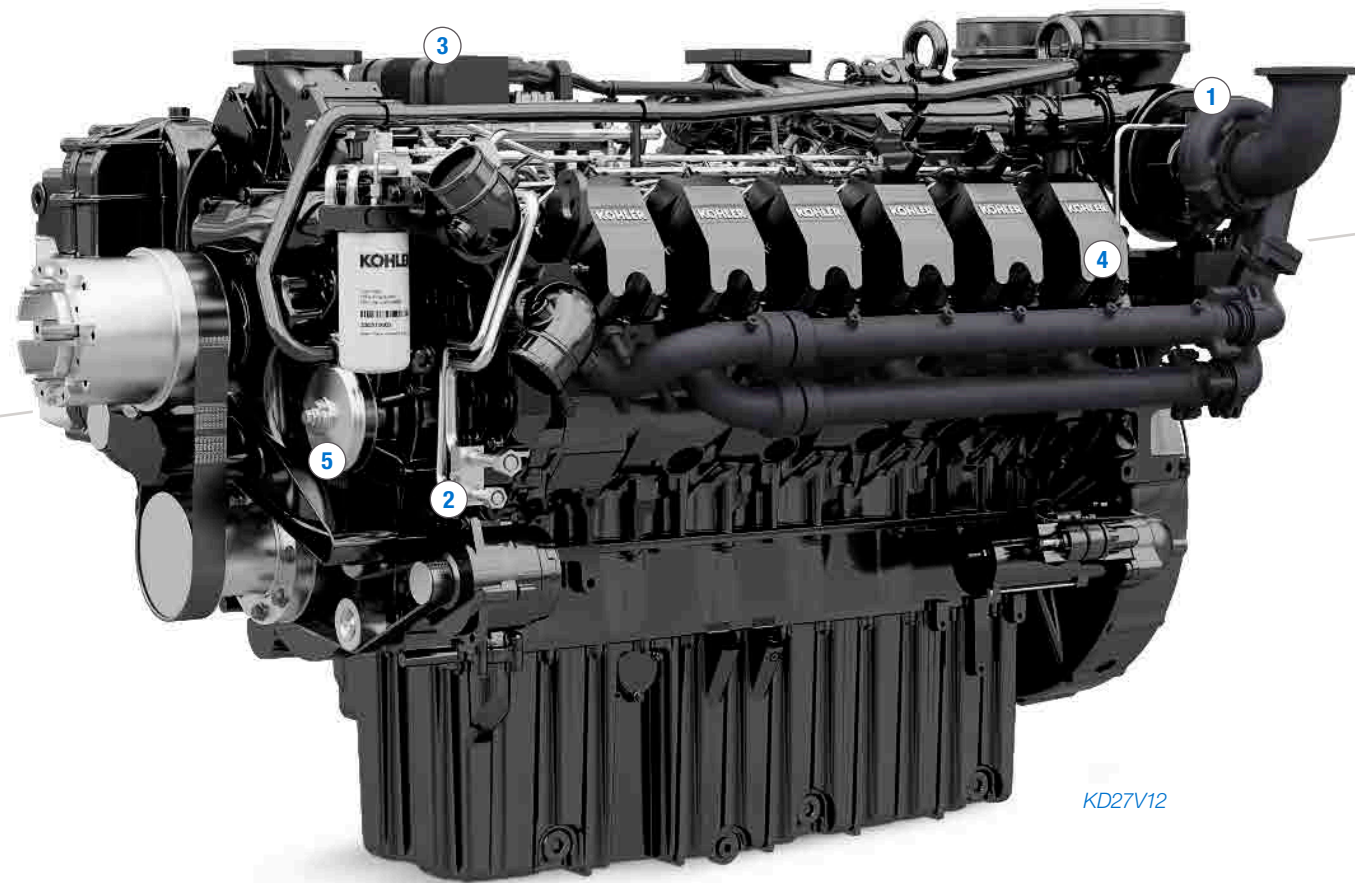

KD27V12

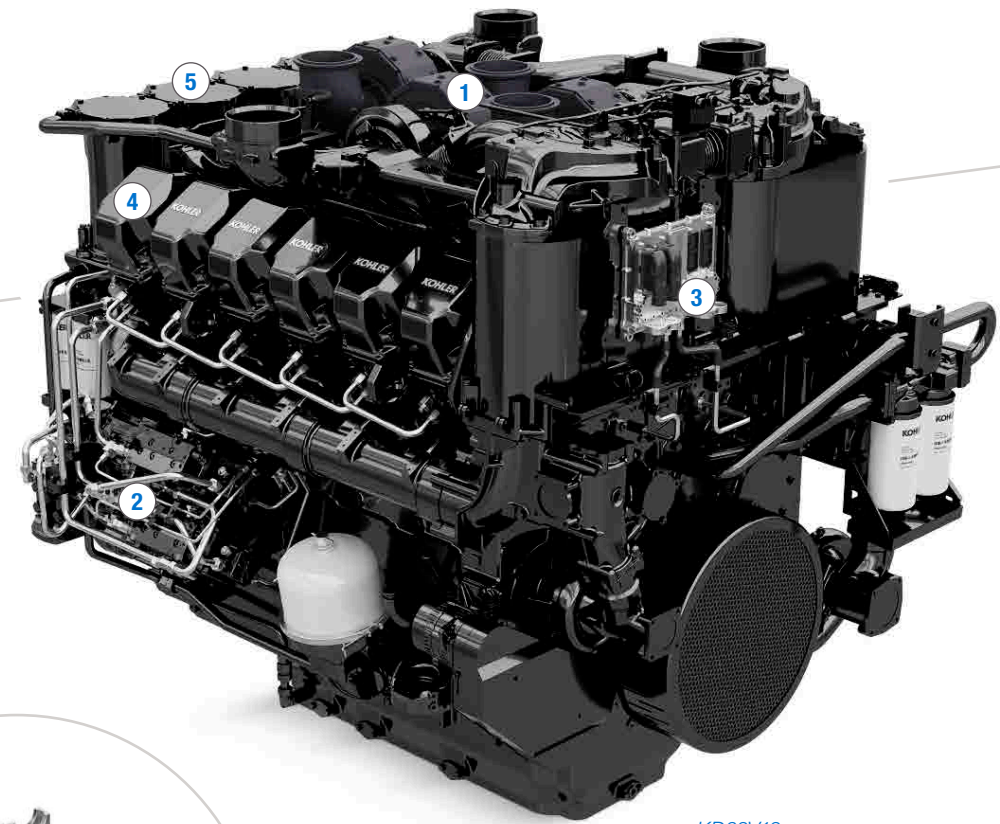

KD62V12

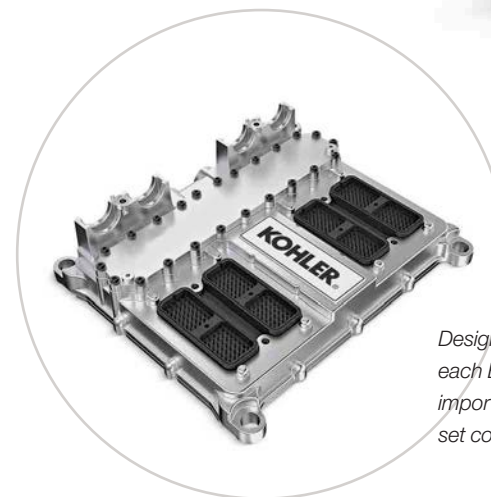

Designed and developed specifically for this engine series, each ECU works with the generator set controller—receiving important engine operating data and allowing the generator set controller to manage the entire system.

# INNOVATION

## 1 MATCHED TURBOCHARGERS

Turbochargers have been designed for maximum power and optimal combustion. They are specifically matched to each engine and engineered to provide the required amount of air at all times, which reduces fuel consumption and enables operation at high altitudes.

## 2 FUEL SYSTEM

The common rail fuel system generates up to 2200-bar injection pressures for maximum efficiency, optimizing the combustion pressure curve through multiple injections. An ideal injection point and extremely uniform injection quantity create exceptionally low noise and deliver very stable power. Engineers specifically designed the remarkable fuel system to work optimally for KOHLER® G-Drive engines.

## 3 INTUITIVE ENGINE CONTROL UNIT (ECU)

The ECU includes a number of physical parameters for optimal control of the injection system and long-life service. It is designed to work seamlessly within the generator set and to communicate with KODIA, our intuitive diagnostic software, to allow monitoring of the engine performance.

## 4 INNOVATIVE CYLINDER HEAD DESIGN

Featuring a “crossflow” design and new valve orientation, our innovative cylinder head design includes more efficient fuel delivery, combustion and exhaust gas flow—materials chosen for better performance and a strengthened structure.

## 5 CRANKCASE VENTILATION

Enhanced crankcase ventilation enables our engines to operate under the highest temperature fluctuations and prevents heat from affecting power output. This closed-loop regeneration system increases filtration efficiency and results in a more environmentally friendly engine.

# **BUILT TO PERFORM,**

## **RIGID ENGINE DESIGN**

Optimized to reduce noise and oscillation levels, our diesel engines feature an extremely stiff engine block, crankcase, oil sump, valve cover and subframe design.

## **INTERNAL COMPONENT DESIGN**

Featuring one-piece steel pistons, our engines allow high ignition pressures with a long service life and deliver maximum strength even under high thermal load. All components, optimized with the finite element analysis, demonstrate ideal load distribution and optimal material utilization.

## **HIGH-QUALITY, LONG-LASTING MATERIALS**

Along with a variety of safety factors, our engines are equipped with the highest-quality materials. For example, composite bearing shells ensure the longevity of crankshaft bearings under increasing loads.

*Optimized gear pairing facilitates low-noise transmission.*

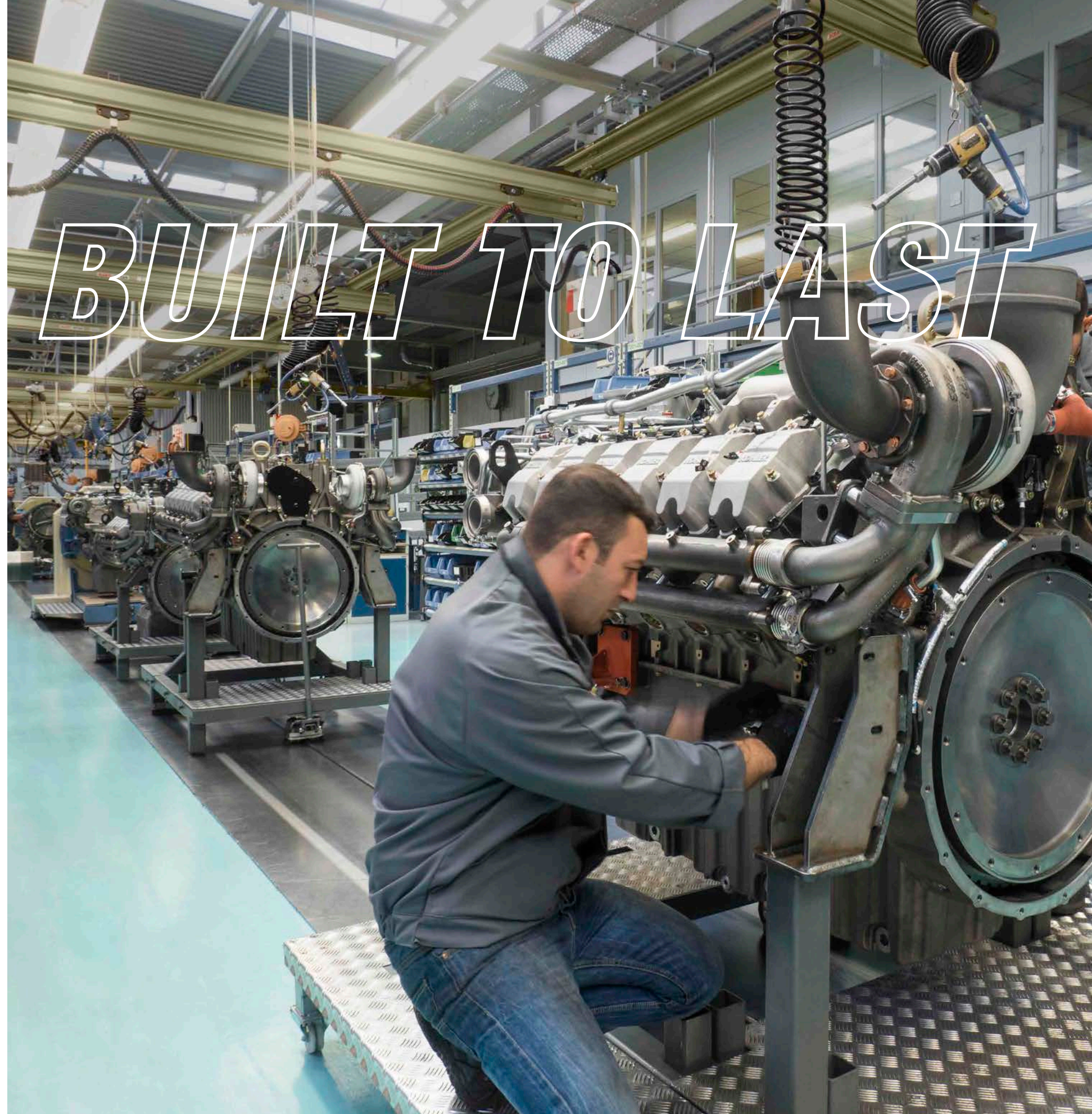

# **BUILT TO LAST**

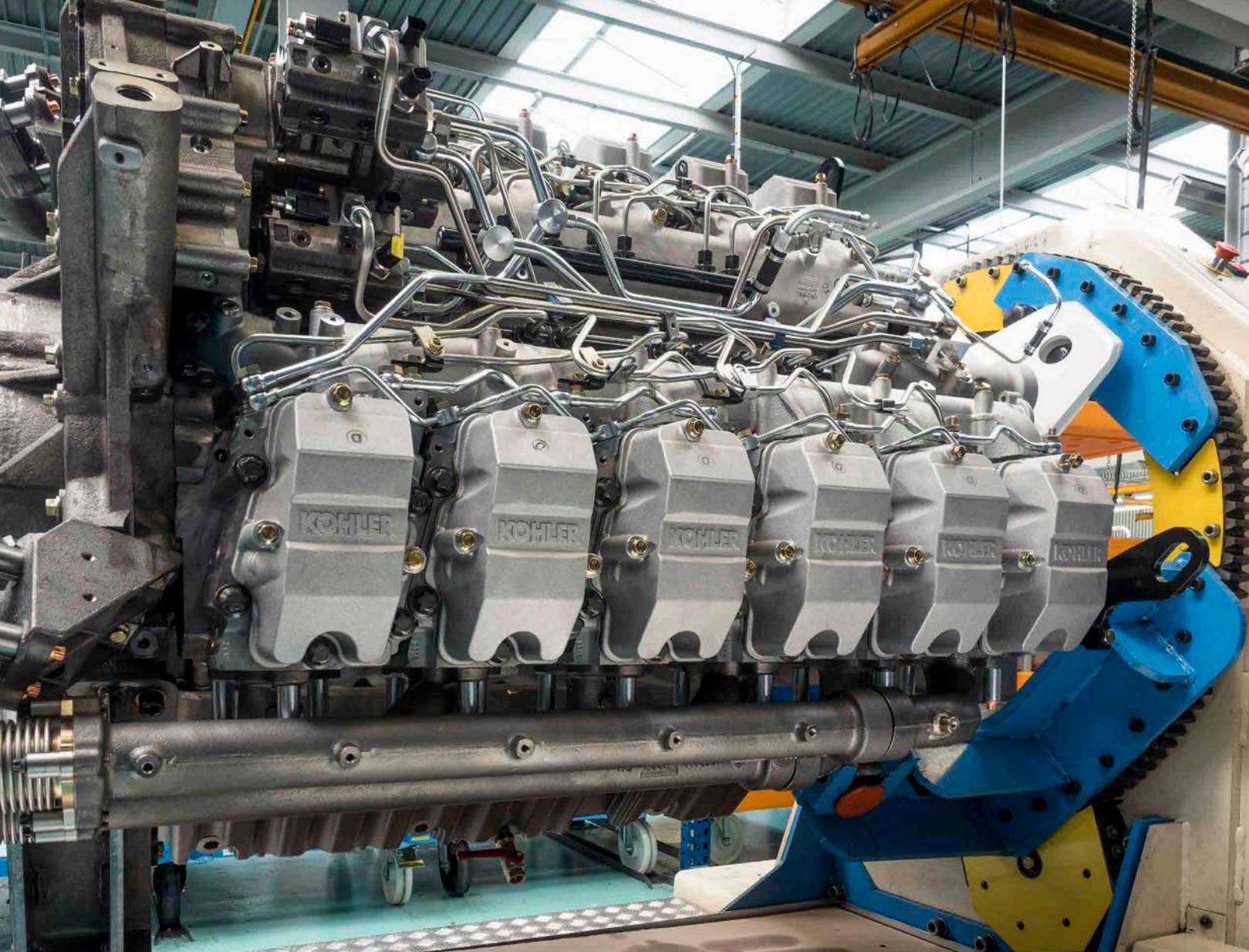

# STATE-OF-THE-ART MANUFACTURING AND DEVELOPMENT

KOHLER® G-Drive diesel engines are manufactured in European factories with the highest-quality manufacturing systems. They have been specially developed over a six-year period for use in generator set applications. These engines are ideal for all types of stringent applications such as data centers, hospitals, power plants and mining sites. They have proven their reliability, efficiency and outstanding performance during nearly 50,000 hours of tests, both in laboratory and on-site.

## HIGHEST STANDARDS OF QUALITY

To safeguard quality, the production plants use a contemporary computer-assisted quality management (CAQ) system that is implemented early in the production creation process and throughout the entire product lifecycle. Statistical assessments, failure mode and effects analysis (FMEA), continual improvement process (CIP), lean management and the 8-D method are implemented to ensure consistent manufacturing processes.

Every engine part—and every engine—is tested under rigorous operating conditions before leaving the factory. DIN EN ISO 9001/2008 standard requirements are followed in France and Switzerland engine manufacturing plants. Consistent quality assurance and process monitoring lead to our engines high level of reliability.

## FINITE ELEMENT ANALYSIS

Using finite element analysis (FEA), our engines optimize the rigidity and weight distribution of connecting rods, crankshafts, engine blocks and other critical components to ensure engine stability.

## MODERN MEASURING DEVICES

Machines that measure 3-D with microrange accuracy offer the best prerequisites for attaining the quality you expect. In addition to inspecting internally manufactured parts, these machines are also used to inspect any parts brought in from external suppliers.

# KD SERIES™ RANGE SPECS

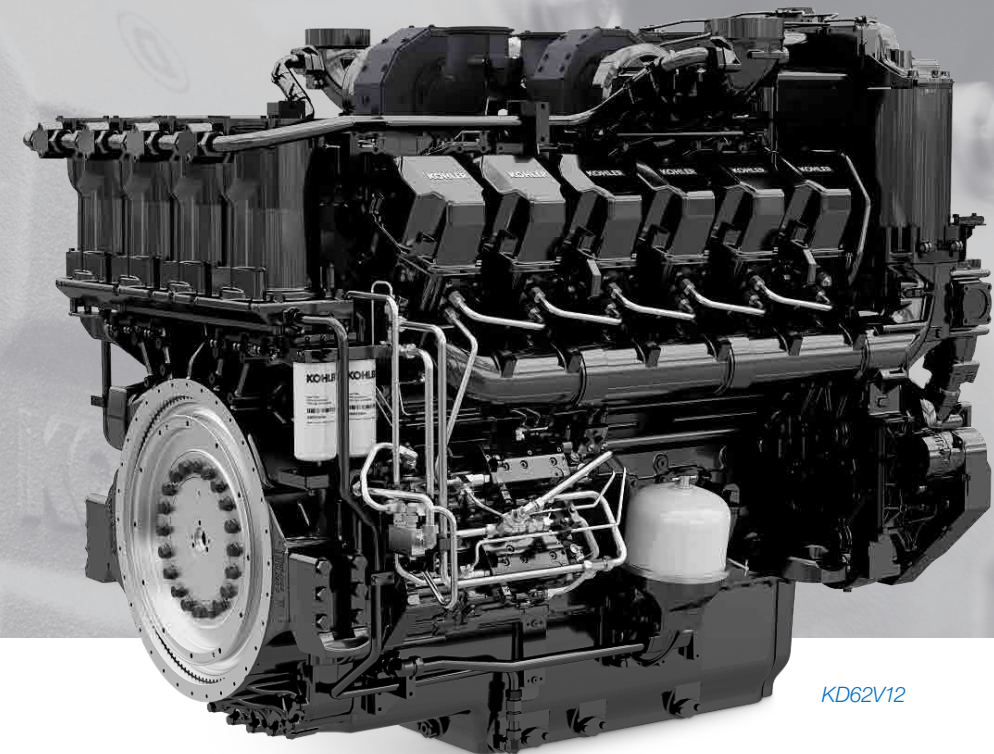

KD62V12

## KD27V12

## KD36V16\*

## KD45V20

GENERAL DATA				
<b>Number of cylinders</b>		12	16	20
<b>Cylinder arrangement</b>		90° V	90° V	108° V
<b>Cycle</b>		4-cycle	4-cycle	4-cycle
<b>Bore</b>	mm (in)	135 (5.3)	135 (5.3)	135 (5.3)
<b>Stroke</b>	mm (in)	157 (6.2)	157 (6.2)	157 (6.2)
<b>Displacement</b>	total l (cu in)	27.00 (1647.6)	36.00 (2196.9)	45.00 (2746.1)
<b>Dimensions L x W x H</b>	mm (in)	2022 x 1356 x 1343 (79.6 x 53.4 x 52.9)	2715 x 1336 x 1426 (106.9 x 52.6 x 56.1)	3087 x 1414 x 1547 (121.5 x 55.7 x 60.9)

GROSS POWER				
<b>1500 RPM (50 Hz)</b>	kWm/BHP	979/1313	1333/1788	1547/2075
<b>1800 RPM (60 Hz)</b>	kWm/BHP	1114/1494	1391/1865	1910/2561

EMISSION CERTIFICATION	
<b>1500 RPM (50 Hz)</b>	
<b>Standby power</b>	Exhaust emission EPA Tier 2 (not certified)
<b>Prime power</b>	Exhaust emission EPA Tier 2 (not certified)
<b>Continuous power</b>	Fuel-optimized
<b>1800 RPM (50 Hz)</b>	
<b>Standby power</b>	U.S. EPA Nonroad Tier 2 stationary (40 CFR 60)
<b>Prime power</b>	U.S. EPA Nonroad Tier 2 stationary (40 CFR 60)
<b>Continuous power</b>	Fuel-optimized

\*Coming soon.

## KD62V12

## KD83V16\*

## KD103V20\*

GENERAL DATA				
<b>Number of cylinders</b>		12	16	20
<b>Cylinder arrangement</b>		60° V	60° V	60° V
<b>Cycle</b>		4-cycle	4-cycle	4-cycle
<b>Bore</b>	mm (in)	175 (6.9)	175 (6.9)	175 (6.9)
<b>Stroke</b>	mm (in)	215 (8.5)	215 (8.5)	215 (8.5)
<b>Displacement</b>	total l (cu in)	62.04 (3785.9)	82.72 (5042.9)	103.40 (6309.9)
<b>Dimensions L x W x H</b>	mm (in)	2661 x 1753 x 2126 (104.8 x 69.0 x 83.7)	3500 x 1754 x 2126 (137.8 x 69.1 x 83.7)	4100 x 1754 x 2200 (161.4 x 69.1 x 86.6)

GROSS POWER				
<b>1500 RPM (50 Hz)</b>	kWm/BHP	2406/3227	3007/4032	3608/4838
<b>1800 RPM (60 Hz)</b>	kWm/BHP	2700/3619	3490/4680	4250/5699

EMISSION CERTIFICATION	
<b>1500 RPM (50 Hz)</b>	
<b>Standby power</b>	Exhaust emission EPA Tier 2 (not certified)
<b>Prime power</b>	Exhaust emission EPA Tier 2 (not certified)
<b>Continuous power</b>	Fuel-optimized
<b>1800 RPM (50 Hz)</b>	
<b>Standby power</b>	U.S. EPA Nonroad Tier 2 stationary (40 CFR 60)
<b>Prime power</b>	U.S. EPA Nonroad Tier 2 stationary (40 CFR 60)
<b>Continuous power</b>	Fuel-optimized

\*Coming soon.

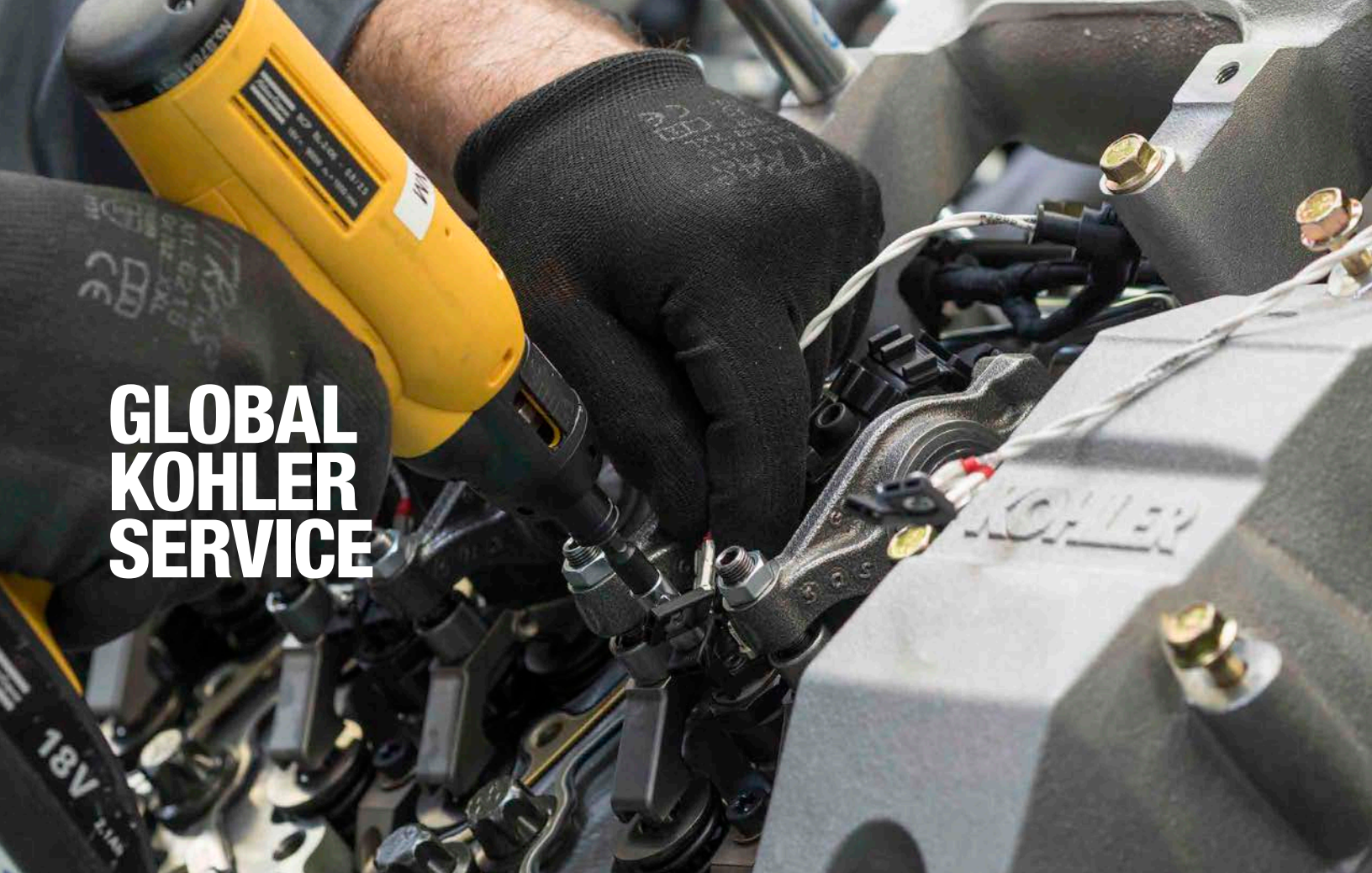

# GLOBAL KOHLER SERVICE

Behind every KOHLER® Diesel G-Drive engine, there's a world of support. Numerous distributors, sales and service locations, and parts distribution centers make up our network, which extends across the globe. Plus, it's all backed by instant online access to everything from parts information to product warranties.

## DAY-TO-DAY EXPERT ASSISTANCE

Kohler provides comprehensive support to engine technicians worldwide by offering:

- Commissioning
- Scheduled and unscheduled maintenance
- Repairs
- Technical documentation
- Product training

## OUR SUPPORT CAPABILITIES INCLUDE:

- Factory-trained technicians equipped with advanced diagnostics and repair tools
- Extended large-engine certification program for field technicians
- 24/365 KOHLER service



## QUALIFYING TRAINING WITH OUR PRODUCT EXPERTS

For advanced training, Kohler has four training centers based in North America, Europe and Asia. These dedicated facilities contain all the necessary resources: teaching rooms, mechanical workshops, test benches, simulators and engine emulators—all to provide participants with hands-on experience.

## SPARE PARTS AND CONSUMABLES

Parts required for maintenance and repair are stored in warehouses strategically located around the world. We also draw on an international distribution network and dedicated personnel with specialized tools to ensure quick availability.

KOHLER genuine parts work in perfect harmony with your engine, maximizing engine performance, prolonging engine life and protecting your investment. Superior design and top-quality materials result in maximum power, longevity and low total-cost of operation. As a result, they enhance your peace of mind, increase uptime and lower maintenance costs.

A modular system allows us to scale the number of components depending on the power required. Using standard components means fewer parts must be stocked in the field and operators require less training. This reduces costs and improves response time.

## DIAGNOSTIC TOOLS

With its self-explanatory user guidance and user-friendly interface, the electronic diagnostic tool KODIA enables a simple and rapid search for malfunctions and faults.

- Engine parameter recording with graphic display for postevent analysis
- Chronological error code and event recording
- Load profile calculation
- Engine sensors simulated for commissioning purposes



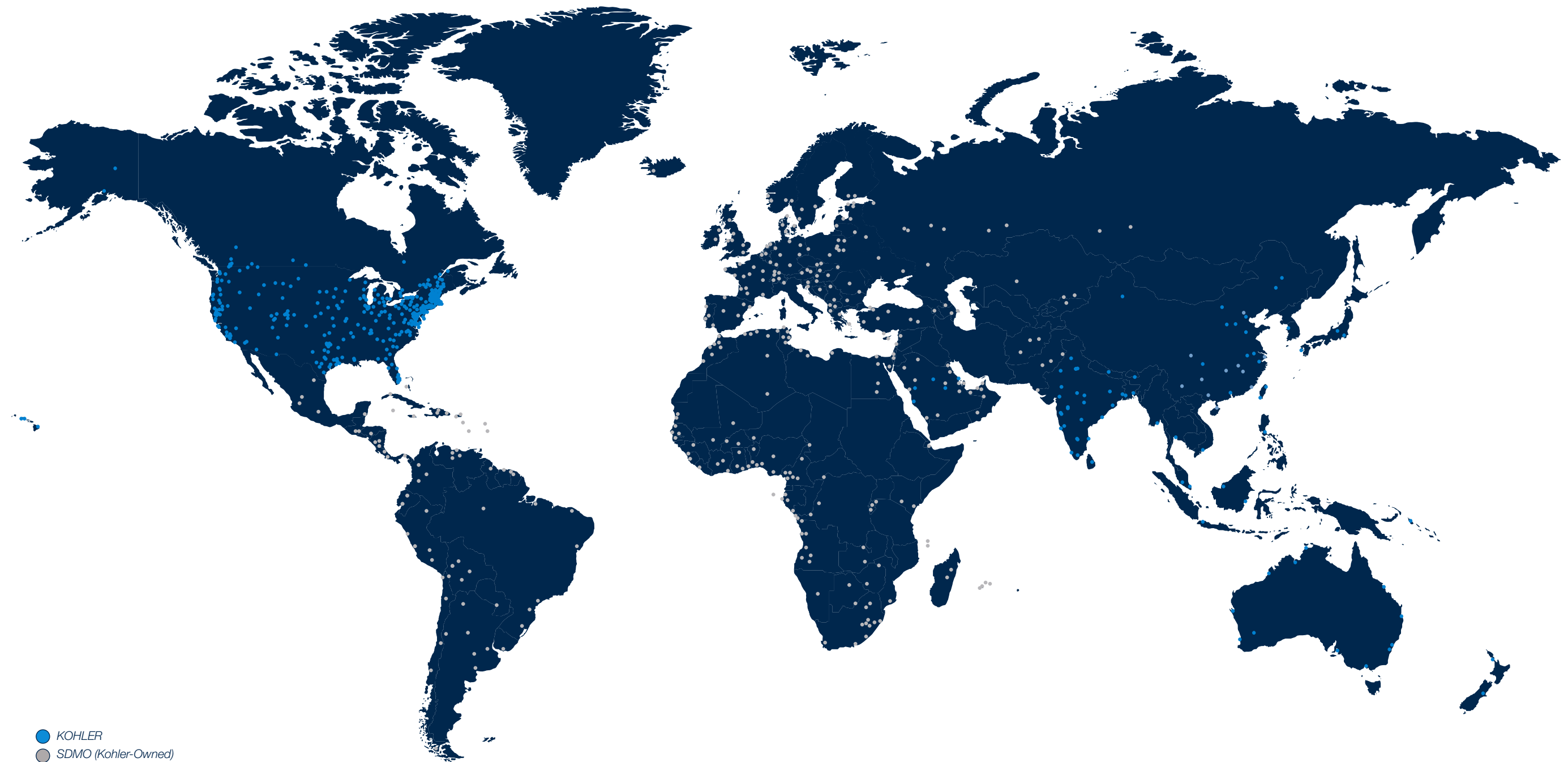

# SERVICE AND SUPPORT.

**The help you need. Anytime, anywhere.**

You're never too far from Kohler. Across the world, more than 800 locations are ready to provide sales, installation and after-market support services. And each one offers expertise in power specifications, equipment and integration. There isn't a question they can't answer. We should know, we trained them ourselves.

Plus, if you ever need assistance in the middle of the night, we'll take care of you. Kohler Power professionals are available to offer troubleshooting, advice, service and support.



## THE GENERATOR ENGINE BUILT BY THE GENERATOR EXPERTS.

A global force in power solutions since 1920, Kohler is committed to reliable, intelligent products, purposeful engineering and responsive after-sale support.

In 2005 we amplified our global reach—acquiring SDMO Industries, a worldwide leader known for its premium ranges of generator sets. Together, we've built on the legacy of two leading brands to create one of the largest global manufacturers of generators in the world—and continued an unwavering focus on reliable power systems and innovation.

Our R&D, manufacturing, sales, service and distribution facilities

span the globe from Kohler, Wisconsin, to Brest, France.

And while we've maintained two world-renowned brand names, today Kohler and SDMO operate as an integrated global organization that's leading the way in design and manufacturing.

We deliver integrated industrial power systems for emergency, prime and continuous applications worldwide—from data centers and hospitals to water treatment facilities and telecommunication sites. With a deep understanding of your industry, we excel in designing customized power systems that simplify your most complex challenges.

## TRUSTED EVERYWHERE

### AMERICAS

North America  
+1 800 544 2444

South America  
+1 (305) 863 0012

### EUROPE

+33 (0)2 98 41 41 41

### MIDDLE EAST

+971 4 458 70 20

### AFRICA

+33 (0)2 98 41 41 41

### ASIA-PACIFIC

Southeast Asia  
+65 6264 6422

China  
+86 400 1808 900

India  
+91 800 266 0600